

SFP-1G-L40-Cxx

1000Base SFP
CWDM
40km Reach

+45 (0)32 72 66 76



info@nexgen.eu



www.nexgen.eu



Features

- Up to 1.25Gb/s data links
- Duplex LC connector
- Hot-pluggable SFP footprint
- Uncooled DFB laser transmitter
- RoHS compliant and Lead Free
- Up to 40km on 9/125um SMF
- Metal enclosure for lower EMI
- Single +3.3V power supply
- Low power dissipation <800mW (0-70°C)
- Low power dissipation <1000mW (-40-85°C)
- Commercial and industrial operating temperature optional
- SFP MSA SFF-8074i Compliant



Applications

- Gigabit Ethernet
- 1x Fiber Channel

Part number	Product description	Note
SFP-1G-L40-Cxx	1000Base SMF SFP CWDM CHxx 40km 0°C to 70°C LC Duplex DDM	1
SFP-1G-L40-Cxx-I	1000Base SMF SFP CWDM CHxx 40km -40°C to 85°C LC Duplex DDM	1

Notes:

1. xx ranging from 27 to 61

PIN Description

PIN	Symbol	Name - Description	Notes
1	VEET	Transmitter Ground (Common with Receiver Ground)	
2	TFAULT	Transmitter Fault. Not supported.	1
3	TDIS	Transmitter Disable. Laser output disabled on high or open.	2
4	MOD_DEF(2)	Module Definition 2. Data line for Serial ID.	1
5	MOD_DEF(1)	Module Definition 1. Clock line for Serial ID.	1
6	MOD_DEF(0)	Module Definition 0. Grounded within the module.	1
7	Rate Select	No connection required	
8	LOS	Loss of Signal indication. Logic 0 indicates normal operation.	3
9	VEER	Receiver Ground (Common with Transmitter Ground)	
10	VEER	Receiver Ground (Common with Transmitter Ground)	
11	VEER	Receiver Ground (Common with Transmitter Ground)	
12	RD-	Receiver Inverted DATA out. AC Coupled	4
13	RD+	Receiver Non-inverted DATA out. AC Coupled	4
14	VEER	Receiver Ground (Common with Transmitter Ground)	
15	VCCR	Receiver Power Supply	
16	VCCT	Transmitter Power Supply	
17	VEET	Transmitter Ground (Common with Receiver Ground)	
18	TD+	Transmitter Non-Inverted DATA in. AC Coupled.	5
19	TD-	Transmitter Inverted DATA in. AC Coupled.	5
20	VEET	Transmitter Ground (Common with Receiver Ground)	

Notes:

- Open collector/drain output, which should be pulled up with a 4.7kΩ to 10kΩ resistor on the host board if intended for use. Pull up voltage should be between 2.0V to 3.6V. A high output indicates a transmitter fault caused by either the TX bias current or the TX output power exceeding the preset alarm thresholds. A low output indicates normal operation. In the low state, the output is pulled to <0.8V.
- Laser output disabled on Tx_Disable >2.0V or open, enabled on Tx_Disable <0.8V.
- LOS is open collector output. Should be pulled up with 4.7kΩ to 10kΩ on host board to a voltage between 2.0V and 3.6V. Logic 0 indicates normal operation; logic 1 indicates loss of signal.
- RD-/+ : These are the differential receiver outputs. They are internally AC-coupled 100Ω differential lines which should be terminated with 100Ω (differential) at the user SERDES.
- TD-/+ : These are the differential transmitter inputs. They are internally AC-coupled, differential lines with 100Ω differential termination inside the module.



Figure 1. Diagram of host board connector block pin numbers and names

Absolute Maximum Ratings

Parameter	Min	Typ	Max	Unit	Notes
Maximum Supply Voltage	-0.3	-	3.6	V	-
Storage Temperature	-40	-	+85	°C	-
Relative Humidity	5	-	95	%	1

Notes:

1. Non-condensing.

Recommend Operation Conditions

Parameter	Min	Typ	Max	Unit	Notes
Power Supply Voltage	3.13	3.3	3.47	V	-
Power Supply Current (com.)	-	-	250	mA	-
Power Supply Current (ind.)	-	-	300	mA	-
Case Operating Temperature (com.)	0	-	+70	°C	-
Case Operating Temperature (ind.)	-40	-	+85	°C	-

Electrical Characteristics

Parameter	Min	Typ	Max	Unit	Notes
Transmitter					
Input differential impedance	-	100	-	Ω	1
Single ended data input swing	250	-	1200	mV	-
TX Disable-High	Vcc-1.3	-	Vcc	V	-
TX Disable-Low	Vee	-	Vee+0.8	V	-
TX Fault-High	Vcc-0.5	-	Vcc	V	-
TX Fault-Low	Vee	-	Vee+0.5	V	-
Receiver					
Single ended data output swing	300	400	800	mV	2
Data output rise time	-	-	175	ps	3
Data output fall time	-	-	175	ps	3
LOS-High	Vcc-0.5	-	Vcc	V	-
LOS-Low	Vee	-	Vee+0.5	V	-

Notes:

1. AC coupled
2. into 100 Ω differential termination
3. 20 - 80%

Wavelength Selection

xx	Center Wavelength	Latch Color	Receiver
27	1271 nm	Blue	APD
29	1291 nm	Blue	APD
31	1311 nm	Blue	APD
33	1331 nm	Blue	APD
35	1351 nm	Blue	APD
37	1371 nm	Blue	APD
39	1391 nm	Blue	APD
41	1411 nm	Blue	APD
43	1431 nm	Blue	APD
45	1451 nm	Blue	APD
47	1471 nm	Gray	PIN
49	1491 nm	Violet	PIN
51	1511 nm	Blue	PIN
53	1531 nm	Green	PIN
55	1551 nm	Yellow	PIN
57	1571 nm	Orange	PIN
59	1591 nm	Red	PIN
61	1611 nm	Brown	PIN

Optical Characteristics

Parameter	Min	Typ	Max	Unit	Notes
Transmitter					
Optical Center Wavelength	$\lambda-6.5$	λ	$\lambda+6.5$	nm	1
Average Output Power	-2.0	-	5.0	dBm	2
Optical Extinction Ratio	9.0	-	-	dB	-
RMS Spectral Width (-20dB)	-	-	1.0	nm	-
Rise/Fall Time	-	-	260	ps	3
Data Rate	-	1.25	-	Gb/s	-
Receiver					
Optical Center Wavelength	1260	-	1620	nm	-
Receiver Sensitivity (PIN)	-	-	-24	dBm	4,5
Receiver Sensitivity (APD)	-	-	-29	dBm	4,5
Damage Threshold (PIN)	0	-	-	dBm	-
Damage Threshold (APD)	-8	-	-	dBm	-
LOS Assert (PIN)	-40	-	-	dBm	-
LOS Assert (APD)	-45	-	-	dBm	-
LOS De-Assert (PIN)	-	-	-28	dBm	-
LOS De-Assert (APD)	-	-	-33	dBm	-
LOS Hysteresis	0.5	-	-	dB	-

Notes:

1. Center Wavelength : "λ" = 1271, 1291, 1311, 1331, 1351, 1371, 1391, 1411, 1431, 1451, 1471, 1491, 1511, 1531, 1511, 1571, 1591, 1611.
2. Class 1 Laser Safety.
3. Unfiltered, 20-80%. Complies with GE and 1x FC.
4. Measured with conformance signals defined in FC-PI-2 Rev. 10.0 specifications.
5. Measured with PRBS 2⁷-1 at 10⁻¹² BER.

Mechanical Dimensions

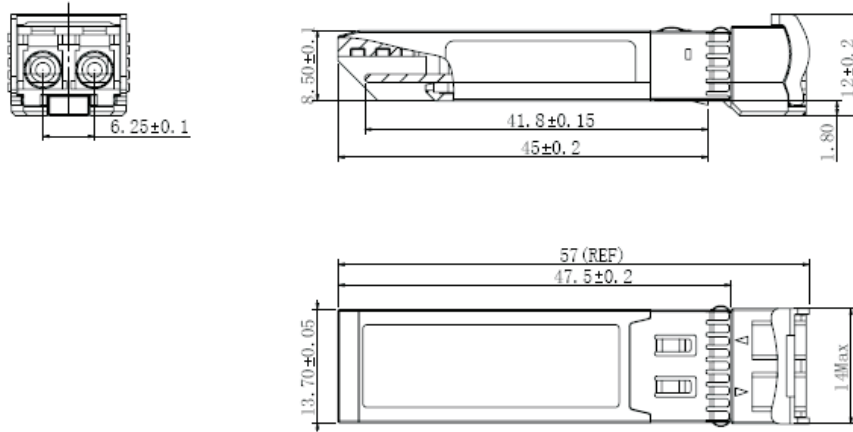

units : mm

Revision history

Revision	Date	Author	Description
V1.1	05-03-2020	JGN	Initial Document

Note : Nexgen A/S reserves the right to change this document without notice.