

# SFP28-25G-SR-DR

10/25GBase SFP28  
850nm  
100m Reach

+45 (0)32 72 66 76

info@nexgen.eu

www.nexgen.eu



## Features

- Supports 10.3125Gb/s & 25.78Gb/s data rate
- Up to 100m transmission on MMF
- Duplex LC Connector
- Hot-pluggable SFP28 footprint
- Built-in digital diagnostic functions
- Single +3.3V power supply
- Power dissipation < 1.0W (0°C to 70°C)
- Power dissipation < 1.2W (-40°C to 85°C)
- Commercial operating case temperature: 0°C to 70°C
- Industrial operating case temperature : -40°C to 85°C
- RoHS Compliant

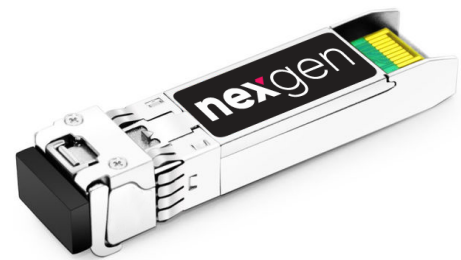

## Applications

- 25G Base-SR
- Data Center

Part number	Product description
SFP28-25G-SR-DR	10/25GBase MMF SFP28 850nm 100m 0°C to 70°C LC Duplex DDM
SFP28-25G-SR-DR-I	10/25GBase MMF SFP28 850nm 100m -40°C to 85°C LC Duplex DDM

# PIN Description

PIN	Symbol	Name - Description	Notes
1	VEET	Transmitter Ground (Common with Receiver Ground)	
2	TFAULT	Transmitter Fault. Not supported.	1
3	TDIS	Transmitter Disable. Laser output disabled on high or open.	2
4	MOD_DEF(2)	Module Definition 2. Data line for Serial ID.	1
5	MOD_DEF(1)	Module Definition 1. Clock line for Serial ID.	1
6	MOD_DEF(0)	Module Definition 0. Grounded within the module.	1
7	Rate Select	No connection required	
8	LOS	Loss of Signal indication. Logic 0 indicates normal operation.	3
9	VEER	Receiver Ground (Common with Transmitter Ground)	
10	VEER	Receiver Ground (Common with Transmitter Ground)	
11	VEER	Receiver Ground (Common with Transmitter Ground)	
12	RD-	Receiver Inverted DATA out. AC Coupled	4
13	RD+	Receiver Non-inverted DATA out. AC Coupled	4
14	VEER	Receiver Ground (Common with Transmitter Ground)	
15	VCCR	Receiver Power Supply	
16	VCCT	Transmitter Power Supply	
17	VEET	Transmitter Ground (Common with Receiver Ground)	
18	TD+	Transmitter Non-Inverted DATA in. AC Coupled.	5
19	TD-	Transmitter Inverted DATA in. AC Coupled.	5
20	VEET	Transmitter Ground (Common with Receiver Ground)	

Notes:

1. Open collector/drain output, which should be pulled up with a 4.7kΩ to 10kΩ resistor on the host board if intended for use. Pull up voltage should be between 2.0V to 3.6V. A high output indicates a transmitter fault caused by either the TX bias current or the TX output power exceeding the preset alarm thresholds. A low output indicates normal operation. In the low state, the output is pulled to <0.8V.
2. Laser output disabled on Tx\_Disable >2.0V or open, enabled on Tx\_Disable <0.8V.
3. LOS is open collector output. Should be pulled up with 4.7kΩ to 10kΩ on host board to a voltage between 2.0V and 3.6V. Logic 0 indicates normal operation; logic 1 indicates loss of signal.
4. RD-/+: These are the differential receiver outputs. They are internally AC-coupled 100Ω differential lines which should be terminated with 100Ω (differential) at the user SERDES.
5. TD-/+: These are the differential transmitter inputs. They are internally AC-coupled, differential lines with 100Ω differential termination inside the module.



Figure 1. Diagram of host board connector block pin numbers and names

## Absolute Maximum Ratings

Parameter	Symbol	Min	Typ	Max	Unit	Notes
Maximum Supply Voltage	Vcc	-0.5	-	3.6	V	
Storage Temperature	Ts	-40	-	+85	°C	
Relative Humidity	RH	5	-	95	%	1

### Notes:

1. Non-condensing.

## Recommend Operation Conditions

Parameter	Symbol	Min	Typ	Max	Unit	Notes
Power Supply Voltage	Vcc	3.13	3.3	3.47	V	
Power Supply Current (com.)	Icc	-	-	300	mA	
Power Supply Current (ind.)	Icc	-	-	380	mA	
Power Dissipation (com.)	Po	-	-	1.0	W	
Power Dissipation (ind.)	Po	-	-	1.2	W	
Case Operating Temperature (com.)	Top	0	-	+70	°C	
Case Operating Temperature (ind.)	Top	-40	-	+85	°C	

## Electrical Characteristics

Parameter	Symbol	Min	Typ	Max	Unit	Notes
Transmitter						
Steady State Current	Icc	-	-	300	mA	
Input Differential Impedance	Zin	90	100	110	Ω	
Differential Input Voltage	Vppin	200	-	900	mV	
Receiver						
Output Differential Impedance	Zout	90	100	110	Ω	
Differential Output Voltage	Vppout	100	-	500	mV	

# Optical Characteristics

Parameter	Symbol	Min	Typ	Max	Unit	Notes
Transmitter						
Optical Center Wavelength	$\lambda_C$	840	850	860	nm	
Average Output Power	$P_o$	-8.4	-	2.4	dBm	
Optical Extinction Ratio	ER	2.0	-	-	dB	
RMS Spectral Width (-20dB)	$\Delta\lambda$	-	-	0.65	nm	
Data Rate	-	10.3125	25.78	-	Gb/s	
Receiver						
Optical Center Wavelength	$\lambda_C$	840	-	860	nm	
Stressed Receiver Sensitivity (OMA)	$P_{min}$	-	-	-10.0	dBm	
Receiver Overload	$P_{max}$	3.0	-	-	dBm	
LOS De-Assert	LOSD	-	-	-12	dBm	
LOS Assert	LOSA	-30	-	-	dBm	
LOS Hysteresis	LOSH	0.5	-	-	dB	

**Notes:**

Sensitivity is measured at 25.75 Gbps with 5x10E-5 BER

## Mechanical Dimensions

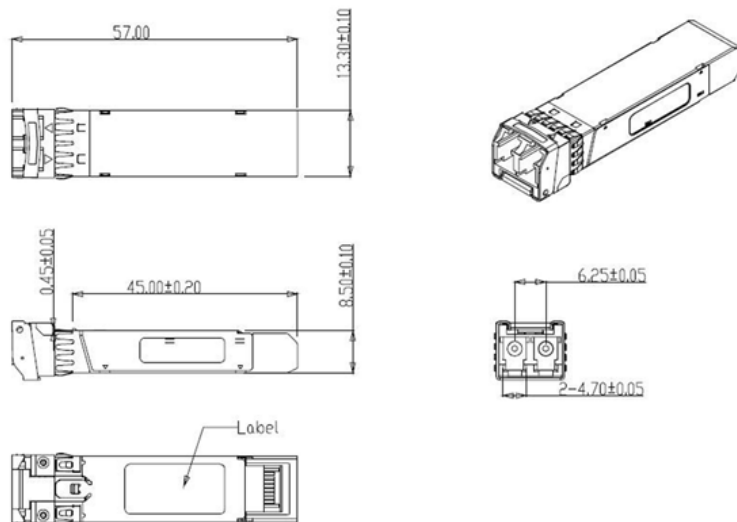

## Revision history

Revision	Date	Author	Description
V1.1	05-03-2020	JGN	Initial Document

Note : Nexgen A/S reserves the right to change this document without notice.