

SFP-25G-SR-I

25GBase SFP28

850nm

100m Reach

Datasheet | product specifications



ESD threshold 1kV for SFI pins and 2kV for all other electrical input pins, tested per MIL-STD-883G, Method 3015.4 /JESD22-A114A (HBM). However, normal ESD precautions are still required during the handling of this module.



Class 1 Laser Product according to IEC 60825-1:2007. This product complies with 21 CFR 1040.10 and 1040.11 except for deviations pursuant to Laser Notice No. 50, dated June 24, 2007. The optical ports of the module need to be terminated with an optical connector or with a dust plug in order to avoid contamination.



Features

- Supports 25GBASE-SR
- Bit rate 25.78 Gb/s
- Up to 70m links on OM3 or 100m links on OM4 on multimode fiber
- VSCSEL laser and PIN receiver
- High speed I/O electrical interface (25GAUI)
- I2C interface with integrated Digital Diagnostic monitoring
- SFP28 MSA package with duplex LC connector
- Single +3.3V power supply
- Case Operating Temperature -40°C to 85 °C



Product may differ from the picture

Applications

- 25GBase-SR Ethernet

Compliances

- Compliant to SFF-8024, SFF-8472, SFF-8432 and SFF-8419
- Complies with EU Directive 2015/863/EU

Overview

Part Number	Transmitter	Input Power	Receiver	Connector	Reach	Temp.
SFP-25G-SR-I	VSCSEL Laser	-8.4 to 2.4 dBm	PIN	Duplex LC	100m	-40°C to 85°C

Ordering Information

Part Number	Product Description
SFP-25G-SR-I	25GBase MMF SFP28 850nm 100m -40°C to 85°C LC Duplex DDM



PIN Description

PIN	Symbol	Name - Description	Notes
1	VEET	Transmitter Ground (Common with Receiver Ground)	
2	TFAULT	Transmitter Fault. Not Supported.	1
3	TDIS	Trnsmitter Disable. Laser output disabled on high or open.	2
4	MOD_DEF(2)	Module Definition 2. Data line for Serial ID.	1
5	MOD_DEF(1)	Module Definition 1. Clock line for Serial ID.	1
6	MOD_DEF(0)	Module Definition 0. Grounded within the module.	1
7	Rate Select	No Connection Required	
8	LOS	Loss of Signal Indication. Logic 0 indicates normal operation.	3
9	VEER	Receiver Ground	
10	VEER	Receiver Ground	
11	VEER	Receiver Ground	4
12	RD-	Receiver Inverted Data Out. AC Coupled	4
13	RD+	Receiver Non-Inverted Data Out. AC Coupled	
14	VEER	Receiver Ground	
15	VCCR	Receiver Power Supply	
16	VCCT	Transmitter Power Supply	
17	VEET	Transmitter Ground	
18	TD+	Transmitter Non-Inverted Data In. AC Coupled	5
19	TD-	Transmitter Inverted Data In. AC Coupled	5
20	VEET	Transmitter Ground	

Notes:

- Open collector/drain output, which should be pulled up with a 4.7kΩ to 10kΩ resistor on the host board if intended for use. Pull up voltage should be between 2.0V to 3.6V. A high output indicates a transmitter fault caused by either the TX bias current or the TX output power exceeding the preset alarm thresholds. A low output indicates normal operation. In the low state, the output is pulled to <0.8V.
- Laser output disabled on TX_Disable >2.0V or open, enabled on TX_Disable <0.8V.
- LOS is open collector output. Should be pulled up with 4.7kΩ to 10kΩ on host board to a voltage between 2.0V and 3.6V. Logic 0 indicates normal operation; logic 1 indicates loss of signal.
- RD-/+: These are the differential receiver outputs. They are internally AC-coupled 100Ω differential lines which should be terminated with 100Ω (differential) at the user SERDES.
- TD-/+: These are the differential transmitter inputs. They are internally AC-coupled, differential lines with 100Ω differential termination inside the module.



Figure 1: Diagram of host board connector block pin numbers and names



Absolute Maximum Ratings

Parameters	Symbols	Min	Typ	Max	Unit	Notes
Storage Temperature	T _s	-40	-	85	°C	
Relative Humidity	RH	5	-	85	%	1
Operating Case Temperature	T _c	-40	-	85	°C	

Notes:

1. Non-condensing.

Recommended Operation Conditions

Parameters	Symbols	Min	Typ	Max	Unit	Notes
Data Rate Per Lane	-	-	25.78	-	Gbps	
Link Distance	D	-	-	70 / 100	m	OM3 / OM4
Power Supply Voltage	V _{cc}	3.13	3.3	3.46	V	
Power Supply Current	I _{cc}	-	-	600	mA	
Power Consumption	P _o	-	-	2	W	

Optical Characteristics

Parameters	Symbols	Min	Typ	Max	Unit	Notes
Transmitter						
Center Wavelength	λ_C	840	850	860	nm	
Spectral Width	I _{rms}	-	-	0.6	dBm	
Average Launch Power	PAVG	-8.4	-	2.4	mA	
Side Mode Suppression Ratio	SMSR	30	-	-	dB	
Extinction Rate	ER	2	-	-	dB	
Receiver						
Optical Input Wavelength	λ_C	840	850	860	nm	
Optical Input Power	P _{in}	-10.3	-	2.4	dBm	
LOS Assert	LOSA	-	-	-30	dBm	
LOS De-Assert	LOSD	-	-	-12	dBm	
LOS Hysteresis	LOSH	0.5	-	5	dB	



Mechanical Dimensions

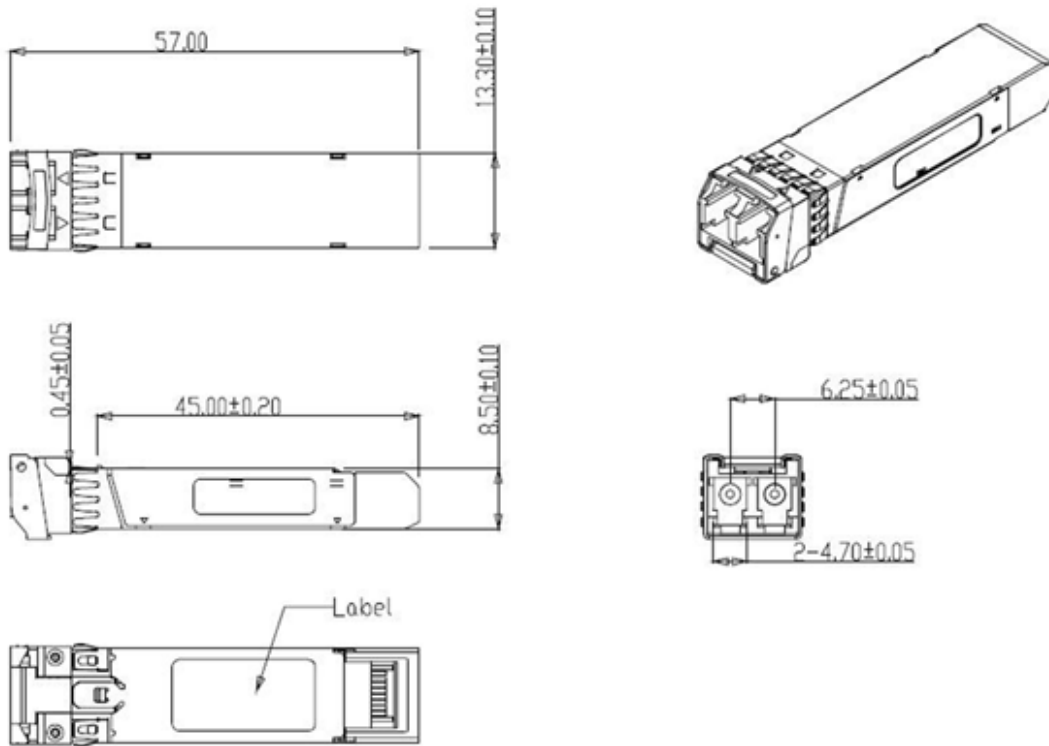

Revision History

Revision	Doc. #	Date	Author	Description
Verson 1.0	DT000100	10/16/2023	SHN	Initial Document

Note: Nexgen A/S reserves the right to change this document without notice.